

#20360

Assembly Instructions
Instructions d'assemblage
Instrucciones para el ensamblaje

If you have any questions about this product, or are missing a part, please call us toll-free at 1-800-521-7080 or visit our website rather than return this product to the store.

Si vous avez des questions sur ce produit ou que des pièces manquent, veuillez nous appeler sans frais au 1-800-521-7080 ou visiter notre site Web au lieu de renvoyer le produit au magasin.

Si tiene alguna pregunta sobre este producto o se le ha perdido una pieza, por favor llámenos al número gratuito 1-800-521-7080 o visite nuestro sitio web, en lugar de devolverlo a la tienda.

M-F 7:30 - 4:30 EST www.americanplastictoys.com



799 Ladd Rd.
Walled Lake, MI
48390-0100

KEEP SMALL PARTS, HARDWARE, AND PLASTIC BAGS OUT OF CHILDREN'S REACH.

TOUTES LES PETITES PIÈCES, LA QUINCAILLERIE ET LES SACHETS EN MATIÈRE PLASTIQUE DOIVENT ÊTRE GARDÉS HORS DE PORTÉE DES ENFANTS.

MANTENER LAS PIEZAS PEQUEÑAS, FERRETERÍA Y BOLSAS DE PLÁSTICO FUERA DEL ALCANCE DE LOS NIÑOS.

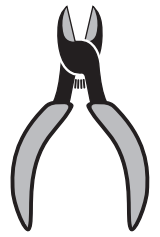

ADULT ASSEMBLY REQUIRED. Tools needed: clippers (not included).
L'ASSEMBLAGE NÉCESSITE UN ADULTE. Outils requis: cisailles (non inclus).
REQUIERE MONTAJE POR UN ADULTO. Herramientas necesarias: alicates (no se incluye).

Toys in contact with food must be washed thoroughly before use.
Les jouets en contact avec de la nourriture doivent être lavés à fond avant usage.
Los juguetes en contacto con la comida deben ser lavados con cuidado antes del uso.

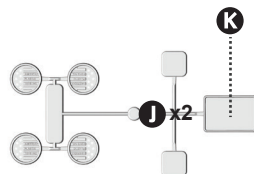
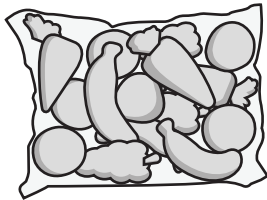
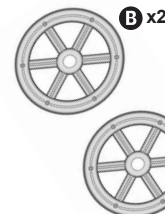
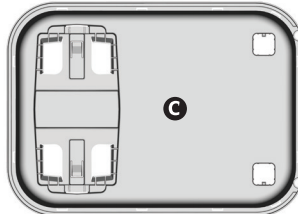
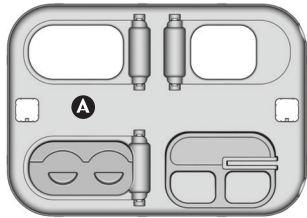

K

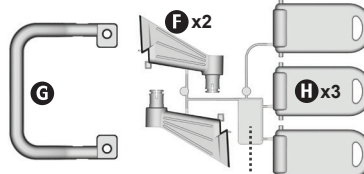

Cluster #2326

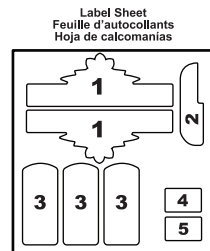

VERY IMPORTANT!
TRÈS IMPORTANT!
¡MUY IMPORTANTE!

Carefully trim all tie bands before assembly.
Découper délicatement toutes les bandes d'attache avant l'assemblage.
Corte todas las cintas de amarre con cuidado antes del montaje.

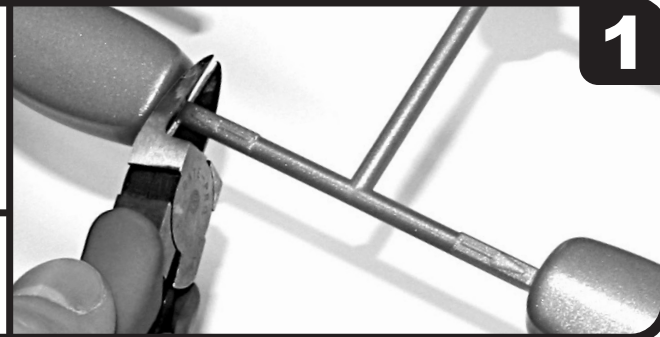

1

→ = snap / emboîter / cerrar a presión
..... = screw / vis / tornillo

2

Clip all cluster parts.
Détachez toutes les pièces de la grappe.
Separe todas las piezas del grupo.

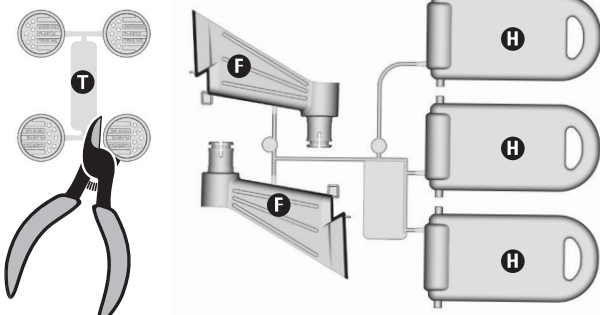

3

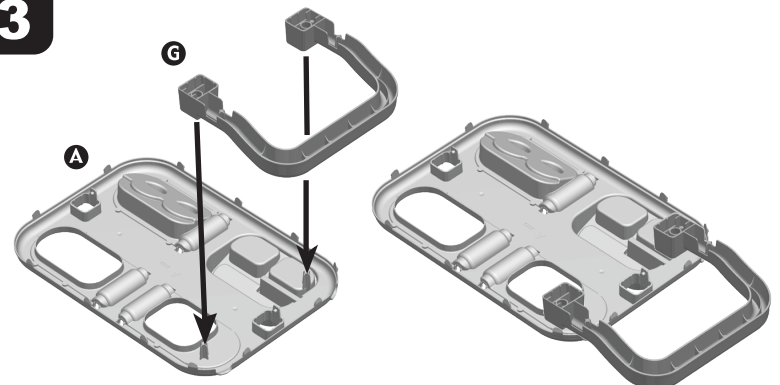

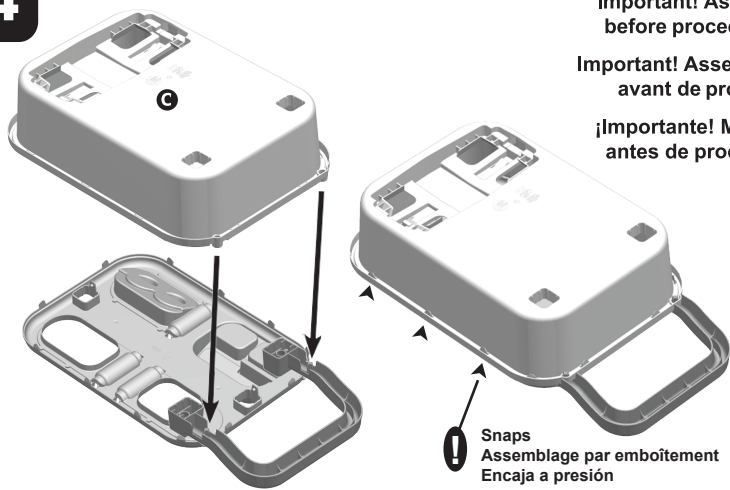
4

! Snaps
Assemblage par emboîtement
Encaja a presión

Important! Assemble parts A and G before proceeding with assembly.

Important! Assemblez les pièces A et G avant de procéder au montage.

¡Importante! Monte las piezas A y G antes de proceder con el montaje

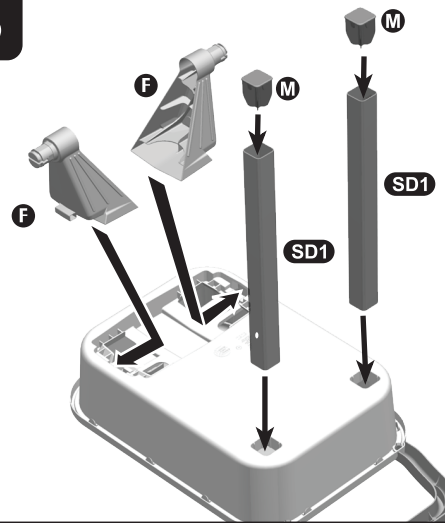
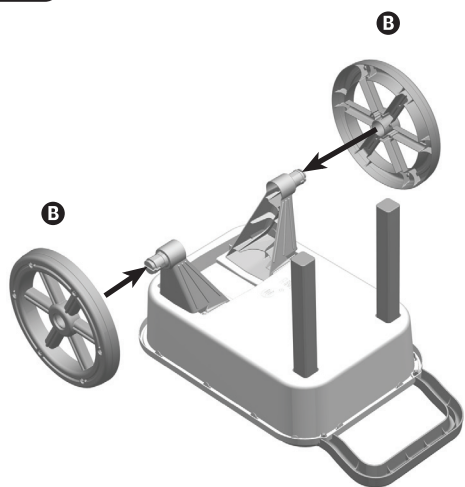
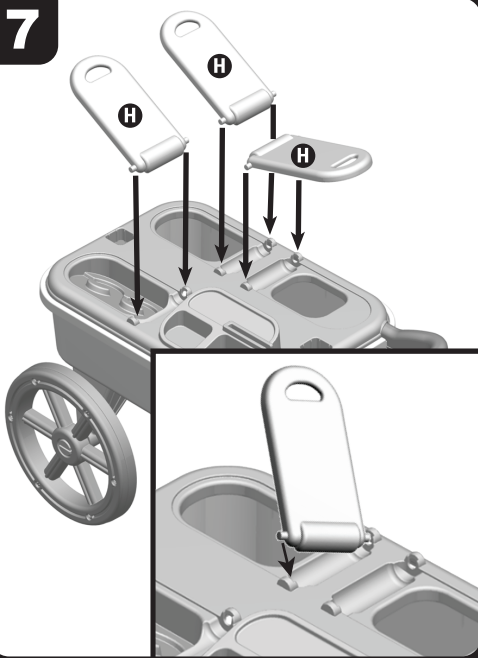
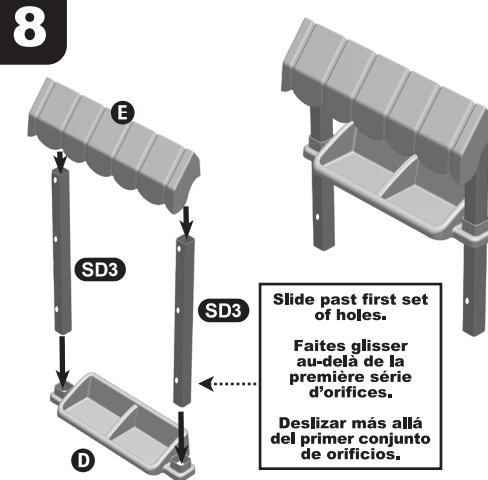
5**6****7****8**

Slide past first set of holes.

Faites glisser au-delà de la première série d'orifices.

Deslizar más allá del primer conjunto de orificios.

Screwdriver
Tournevis
Destornillador

To reposition cone tray, flex tab away from tube and slide.

Pour repositionner le plateau à cornets, pliez la languette pour la dégager du tube et faites-la glisser.

Para volver a colocar la bandeja de barquillos, flexione la lengüeta fuera del tubo y deslicela.

9

! Notice the holes face the same direction as the (cash) register.

Il est à noter la présence d'orifice au bas de chaque pièce.

Observe que los orificios están orientados en la misma dirección que la caja registradora.

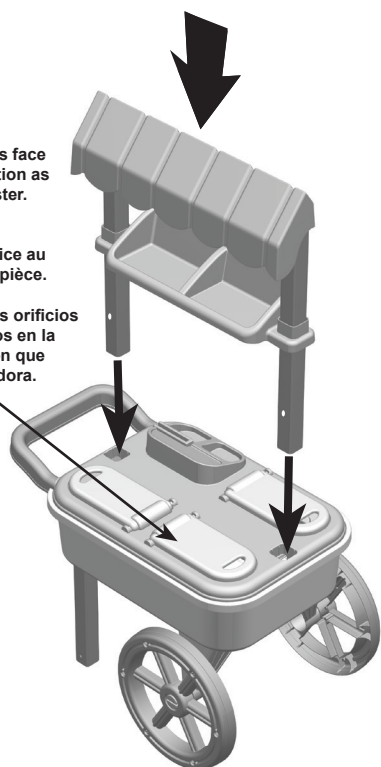
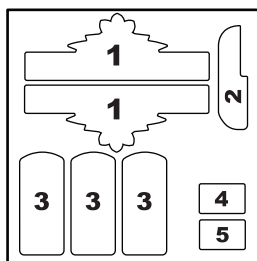
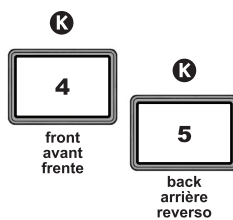
**10**

Label Sheet
Feuille d'autocollants
Hoja de calcomanías

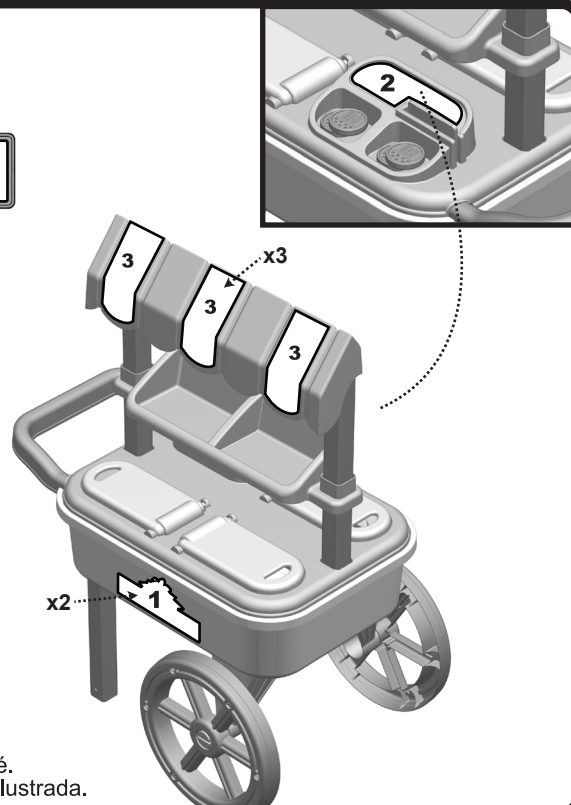

Apply labels as shown.
Appliquer les autocollants tel qu'illustré.
Coloque las calcomanías de la forma ilustrada.